

The logo for FIMAP features a stylized icon on the left consisting of a grid of circles, with the right half of each circle missing, creating a pattern of semi-circles. To the right of this icon, the word "FIMAP" is written in a bold, uppercase, sans-serif font. A registered trademark symbol (®) is positioned at the top right of the letter "P".

**FIMAP**®



PROFESSIONAL  
VERTICAL  
AUTOSCRUBBER



**V1 Professional Autoscrubber. The global solution to clean small and medium floors that fits any environment, space or cramped conditions**

The machine opens up a new segment in the cleaning market. Now you can have the power and performance of a conventional scrubber dryer in a small, nimble and manoeuvrable machine. The era of PROFESSIONAL VERTICAL AUTOSCRUBBERS has begun.

V1 revolutionises the cleaning of small and medium surfaces, bringing the quality of professional cleaning where a conventional scrubber dryer cannot reach.

With V1 you get the high standard of hygiene that only a scrubber dryer can give you, even when space is narrowed by an irregular layout or the presence of obstacles.

**With its exceptional flexibility there is nowhere it cannot go: effortlessly you reach the most hidden corners and complete your cleaning task quickly and successfully.**



## V1, made for professionals!

The **ROBUSTNESS, RELIABILITY** and **POWER** of a conventional scrubber dryer are engineered into a vertical design



### Robust and reliable

- **ALL THE PLASTICS** are highly resistant and shockproof
- Stress-resistant **aluminium WEIGHTLESS JOINT**
- **MACHINE BODY AND SQUEEGEE** in corrosion resistant **ALUMINIUM**
- **BRUSHLESS BRUSH MOTORS** They are a perfect choice for their compact size and very advantageous, as they are **durable** and **maintenance-free**, and are more **efficient**, since they allow the full power output to be used, without dissipation.



### Powerful

- **INTELLIGENT VACUUM MOTOR**, it autonomously adjusts to the amount of water to be collected, **decreasing the vacuum power when it is small and increasing it when it is larger**, optimising battery use so as to extend battery runtime.
- **350 rpm and 30 kg of BRUSH PRESSURE ON THE FLOOR** to tackle the most stubborn dirt and ensure a cleaning quality comparable to or even better than a conventional scrubber dryer.
- **ADJUSTABLE CLEANING POWER**. The amount of water and the vacuum power can be adjusted from the display so that the cleaning power can be changed when dealing with tougher dirt and avoid the need to perform a second cleaning.

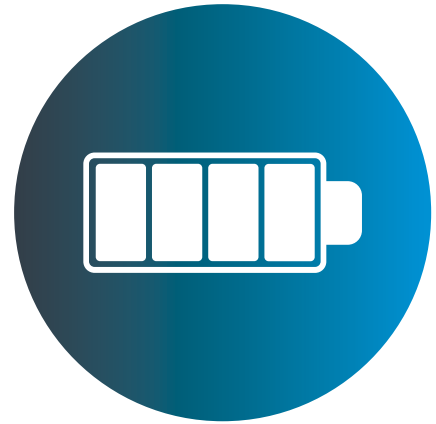

## With high operating time

### LITHIUM BATTERIES

V1 is powered by a lithium battery that **delivers up to 2 hours of runtime\***.

The battery is easy to replace; you can get more than one to alternate charges and always have V1 ready for use.

Lithium batteries offer numerous advantages: no maintenance, long lifespan, and quick charges. They are lightweight and much more efficient than conventional batteries.

**The automatic vacuum motor adjustment helps preserve energy, thus increasing work autonomy.**

### SOLUTION TANK

**With just 1 full tank of water, you can clean for 30 minutes and a floor of 700 sq.m**

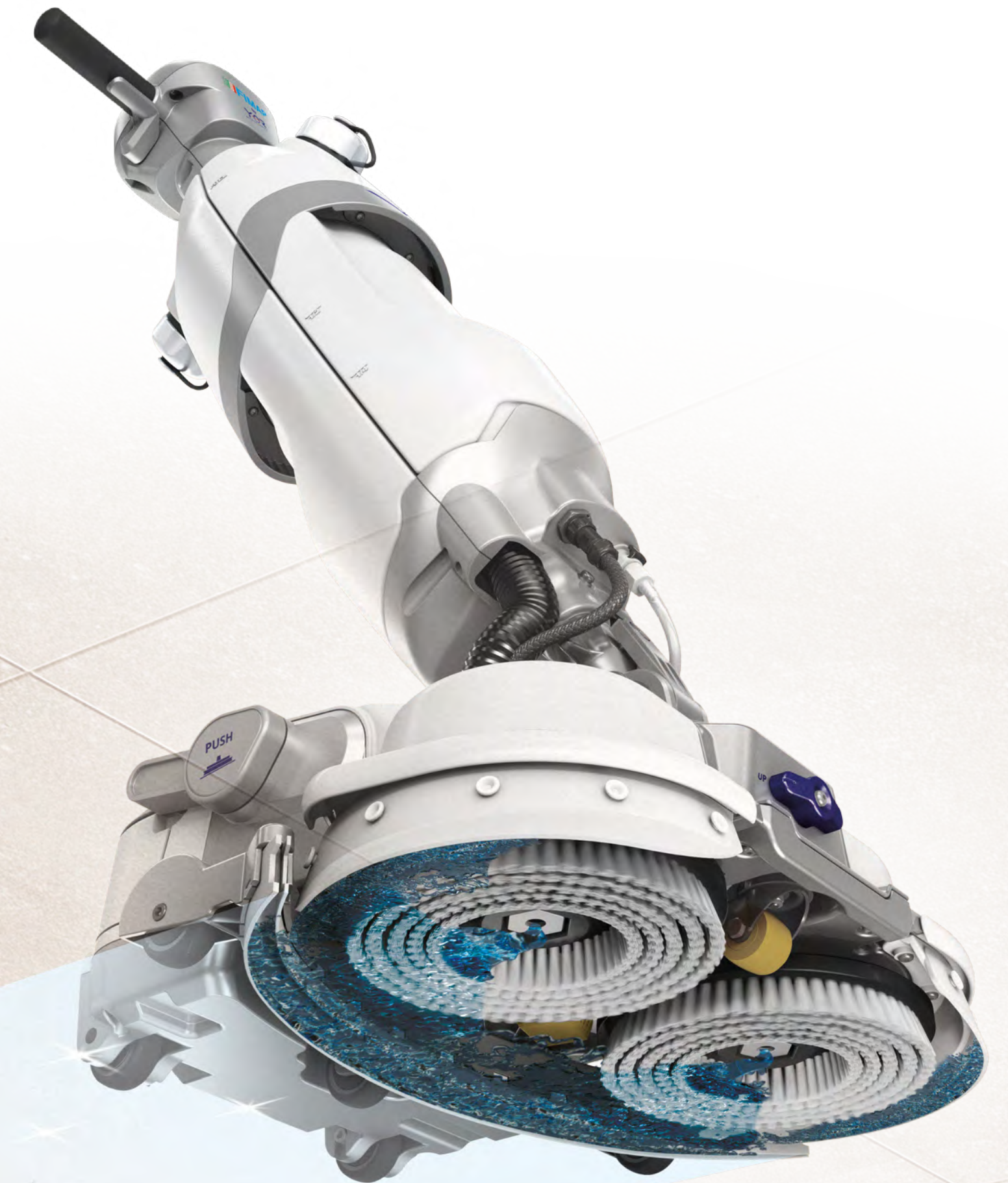

\* Lithium battery (24V / 25 Ah)

**PRO performance  
to tackle the most stubborn dirt**

**1 FRESH WATER TANK**  
Up to **30** minutes of work with 1 full tank of water

**2 FRESH WATER DISPENSING**  
The water dispensing, evenly distributed on the two brushes, ensures uniform floor cleaning

**3 DIE-CAST ALUMINIUM JOINT**  
Corrosion resistant  
**ALUMINIUM FRAME BODY AND SQUEEGEE**

- Counter-rotating brushes at **350** rpm with **Brushless motors**
- Up to **30** kg of pressure on the floor

**FLOAT AND FILTER**  
To protect the vacuum motor

**SHOCKPROOF PLASTIC**

**DIRTY WATER RECOVERY TANK**

**Advanced vacuum technology**  
The exceptional vacuum power quickly collects the cleaning solution and any other liquid. The floor is clean and dry in one pass, and immediately safe to walk on.

**DIRTY WATER VACUUM HOSE**

**POWERFUL VACUUM MOTORS**  
To ensure optimal drying on the first pass

**PARABOLIC SQUEEGEE**

**7**

**6**

**5**

**4**

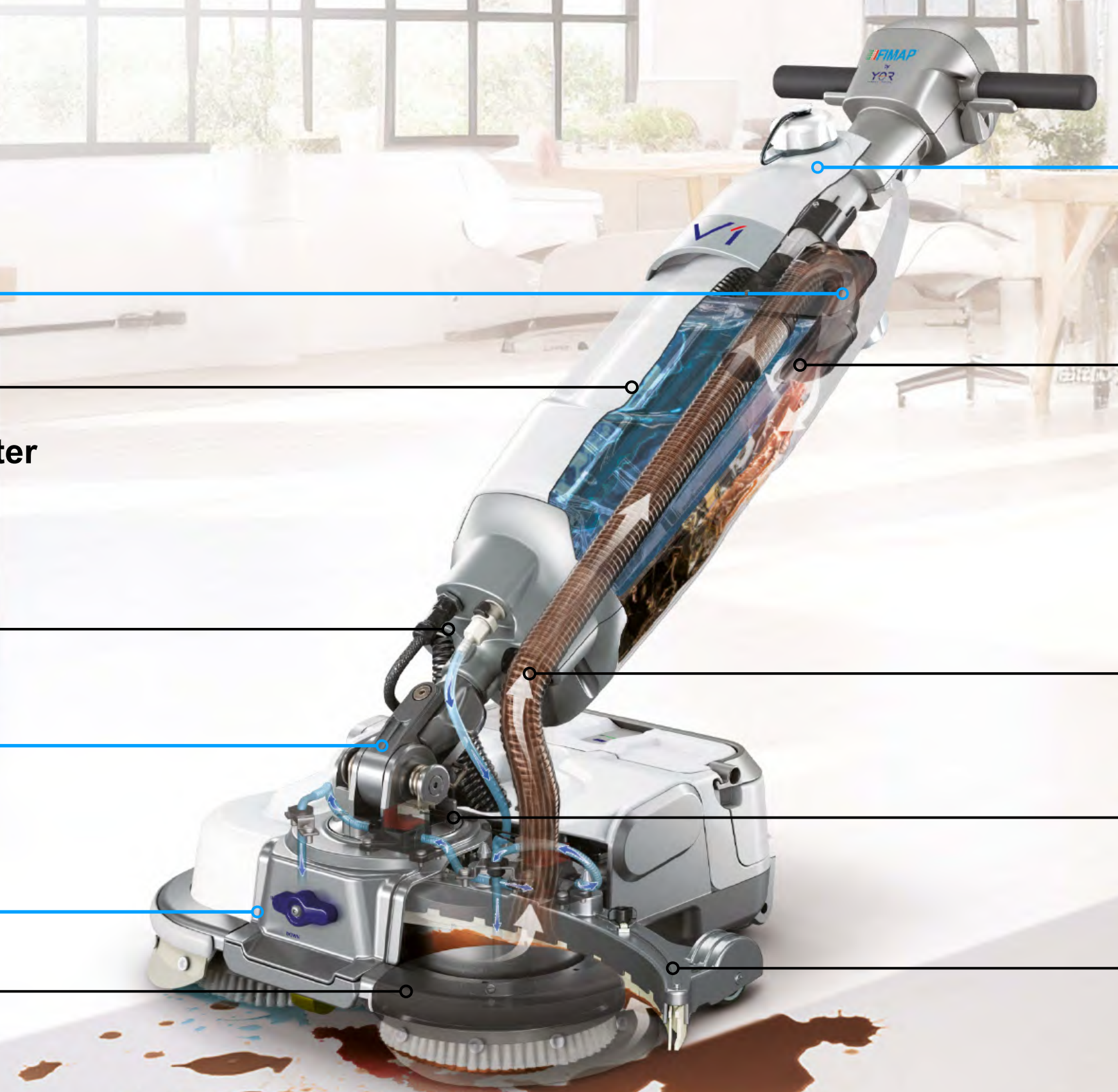

All PRO functions shaped  
in a compact, vertical  
scrubber dryer

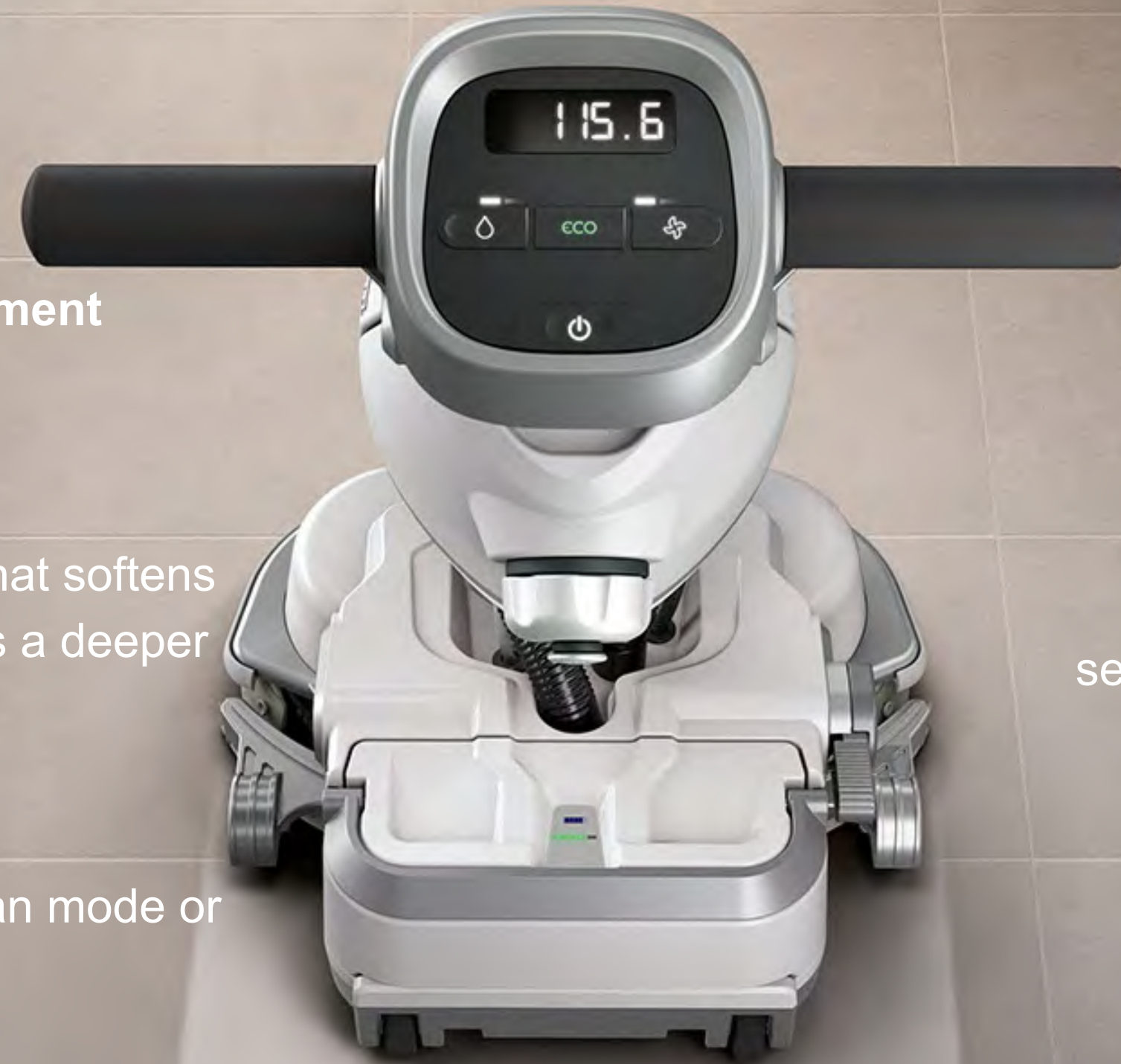

Cleaning modes for any requirement

**1. PRE-CLEAN**

To wet a particularly dirty area, performing a pre-cleaning action that softens the most stubborn dirt and enables a deeper cleaning



**2. DRYING**

To vacuum water from the pre-clean mode or accidentally spilled liquids



**3. SCRUBBING AND DRYING**

Floor scrubbing and drying in a single pass

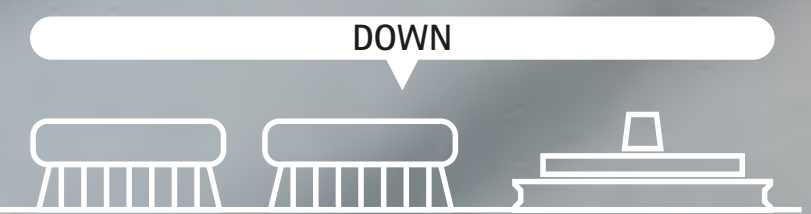

**4. ECO MODE**

A water and energy saving mode suitable for cleaning lightly soiled floors



**Digital hour meter**  
It keeps you updated on usage times and helps you calculate the time needed for cleaning



**Cleaning power adjustment**  
Water distribution and vacuum power can be adjusted separately and at any time during cleaning, according to actual needs



**Service**  
A message on the display advises you when it is time for servicing



**Lithium battery (24 V)**  
It's lightweight, compact and manages energy efficiently, ensuring seamless cleaning sessions

## WEIGHTLESS Technology

V1 is a professional machine that proves all its power and robustness in performance but does not strain the operator during use, thanks to the innovative WEIGHTLESS technology.

The core of the technology is the joint, which manages the machine's balance and supports its weight, so that no strain is felt during manoeuvring, even with a full water tank.

V1 can bend in any direction and achieve very tight turning radii, making it easy to reach the most challenging spots.

### ① Eliminates effort

Ergonomics and manoeuvrability have been taken to the extreme to enable V1 to fulfil its purpose: **to make it easy to clean the most difficult spots without any effort for the operator.**

### ② Stands uprights on its own

If needed, the handle can be locked in the upright position using a lever on the grip. This allows V1 to stand on its own without requiring any additional support.





### ③ 2 Modes of working



#### 1. FIXED HANDLE

##### Conventional use, for FREE AREAS

The handle is fixed to move only forwards and backwards, down to a radius of 30°. The user can adjust the height according to their own and find the most comfortable posture for working without straining the back. The use is that of a conventional floor scrubber. It can cover up to 1500 sq.m/h

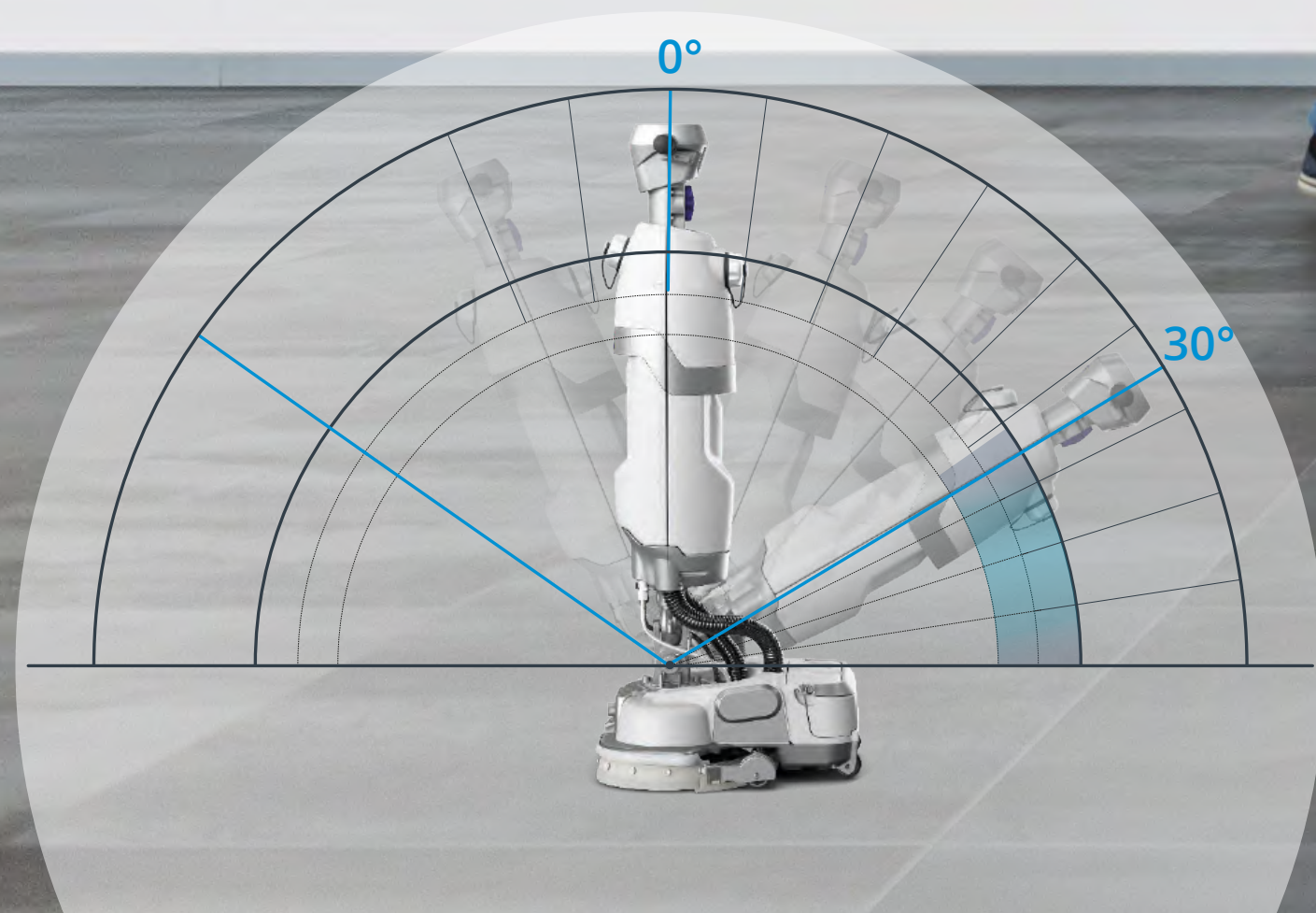

#### 2. FLEXIBLE HANDLE

##### The maximum flexibility, for CRAMPED SPACES

The handle is completely free and can perform any manoeuvre necessary to get around obstacles that clutter the area, bending sideways down to 45° to reach under tables. Maximum freedom of movement that does not fatigue during use is guaranteed by the **Weightless technology**.

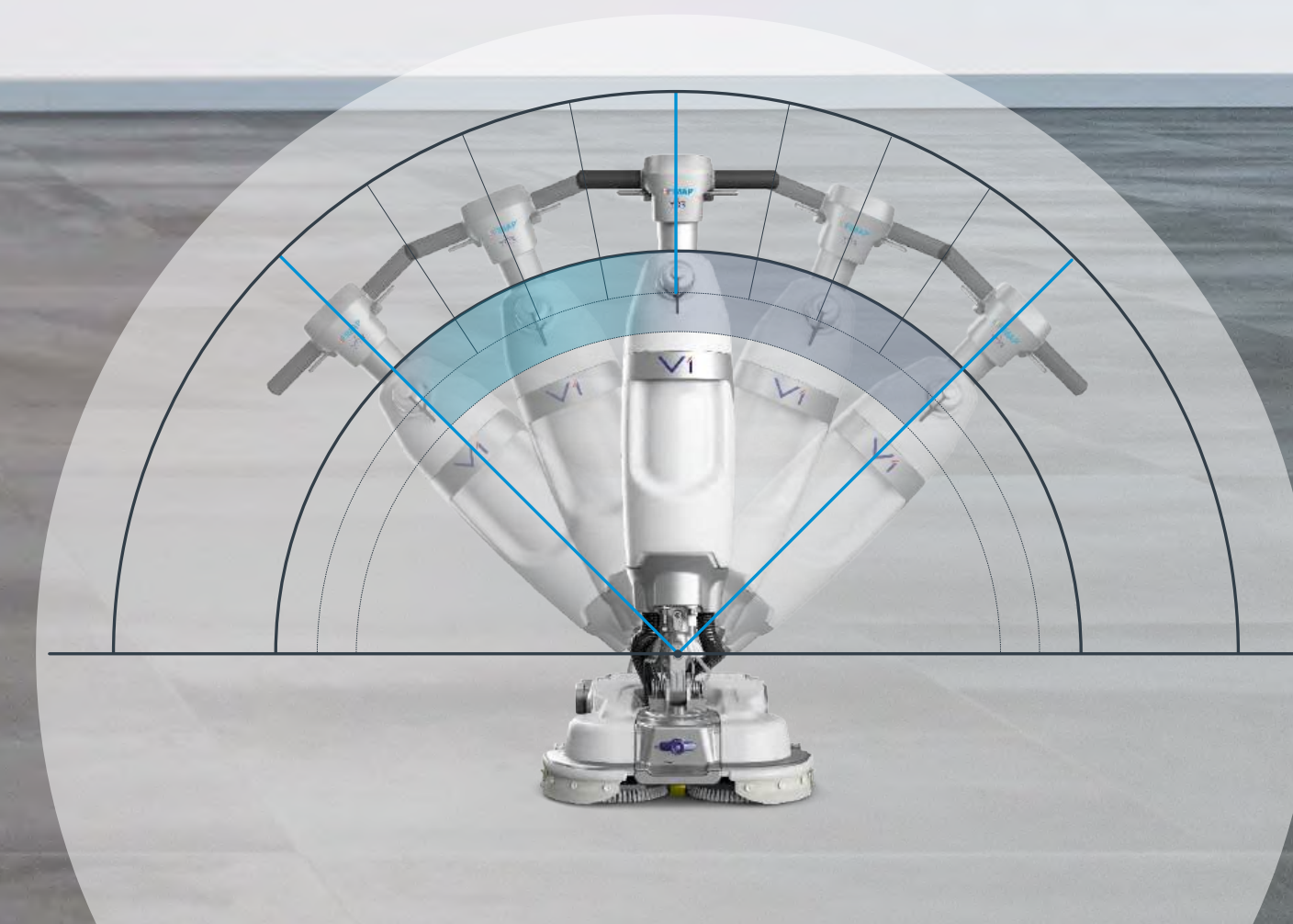

**You can switch from one working mode to another effortlessly,  
just like in a PRO!**

### **QUICK-SQUEEGEE FOOT SWITCH FOR THE SQUEEGEE ACTIVATION**

The **QUICK-SQUEEGEE** device enables the squeegee to be activated via a foot pedal. This allows you to switch from one cleaning mode to another, such as from pre-clean to scrubbing and drying, without bending down or using your hands. It is more hygienic, as it avoids hand contact with the dirty solution on the floor, and more comfortable, because it does not strain your back.



## QUICK-TROLLEY

You can carry it everywhere like a travel trolley without any effort

V1 is perfect for cleaning small areas, but these are not always close to each other. That's why it features a trolley system with wheels placed at the support points, **allowing you to pull or push V1 like a trolley and easily take it where needed.**

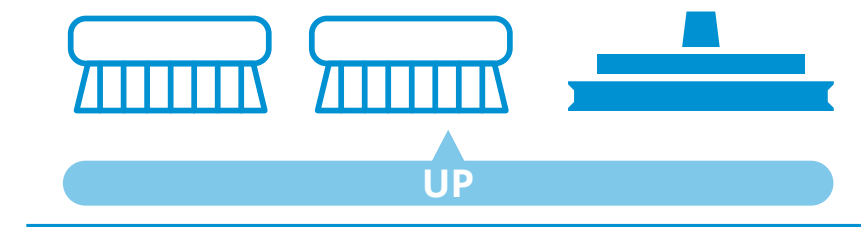

## ERGONOMICS & FUNCTIONALITY



**It takes up little space for storage**

When stored, V1 takes up only the space of the brush head. In the parking position, the front wheel keeps the brushes raised off the ground, preventing the bristles from warping.

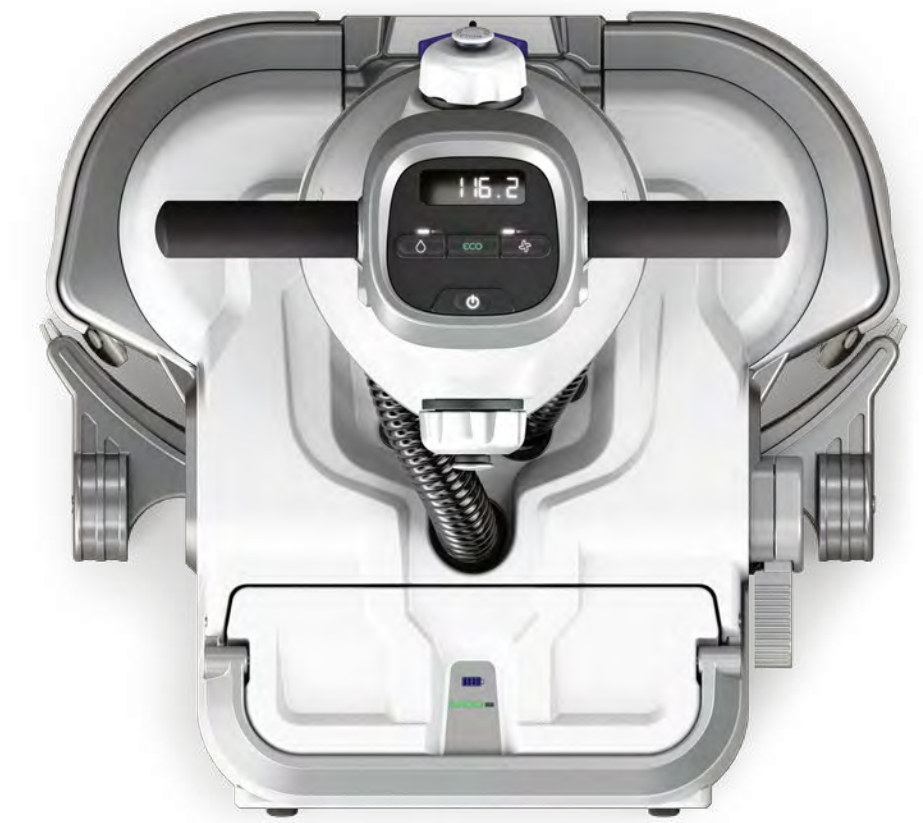

**Easy to transport from one area to another**

V1 is convenient to transport in a car, making it ideal for professionals who need to move it between different buildings.



## It's immediately ready with the **QUICK&SMART** solutions

V1 can be prepared in just a few steps,  
thanks to the intelligent  
**QUICK&SMART** solutions  
for an absolutely user-friendly experience.



**The ECO MODE function allows for immediate startup.**

Press a single button, and water and suction are automatically activated in a saving mode which reduces consumption by up to 40%



**CONVENTIONAL  
FILLING**

The solution tank can be filled by placing it directly under a faucet



**QUICK-TAP DRIP-GUARD  
HOSE**

For greater convenience, you can use the drip-guard hose to fill the tank. Being connected to the faucet, it prevents water from spilling.



**QUICK-DOSE  
MEASURING CAP**

The built-in dispenser allows you to measure the correct amount of detergent



**QUICK-CLIP SOLUTION  
TANK**

The fresh water tank unhooks and re-hooks in a flash, for convenient filling or cleaning



while maintenance is carried out makes operations more comfortable

# Daily maintenance is so quick that it is not a burden, it only takes a little to have V1 always in shape

Regular cleaning after use ensures optimal conditions for consistent performance and extends the lifespan of both individual parts and the entire machine.

Every part that needs cleaning can be removed and reattached without tools. In just a few minutes, your V1 will be ready and in shape for the next use.



## FLOAT AND FILTER

The filter is easy to detach and clean. Regular cleaning helps keep consistent performance

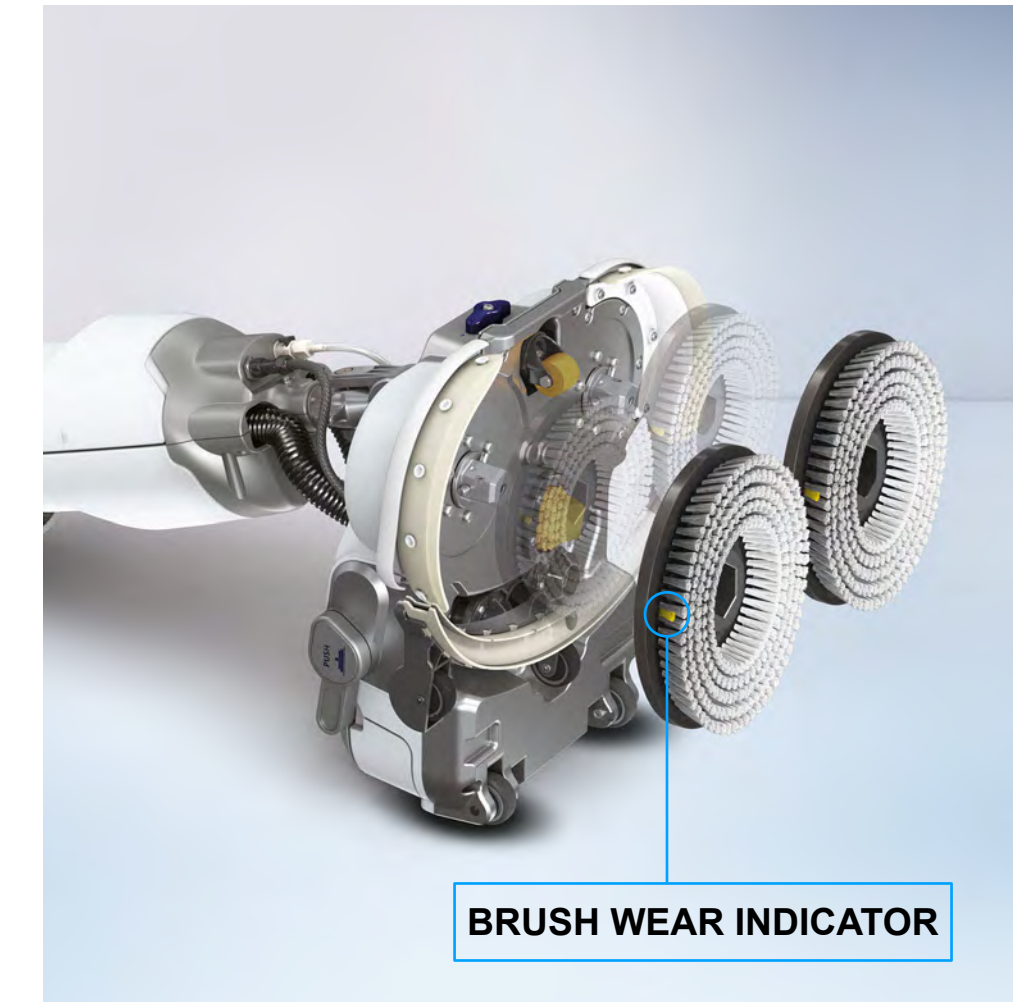

## QUICK-BRUSHES

Maintaining the brushes in good condition is essential for consistent cleaning performance.

**The Brush Wear Indicator system** allows you to visually check the brush wear, so you know when it's time to replace them. Again, no tools are required for the replacement



### **SQUEEGEE CLEANING**

The squeegee is quick and convenient to clean as it can be removed without tools. The blades can be removed just as easily, so that they can be turned and used on all 4 sides



### **BATTERY CHARGER**

The external charger is extremely convenient, as it can be placed wherever it's most suitable for you, without worrying about the machine's bulk. Additionally, by purchasing two batteries you can charge one while using the other, ensuring that V1 is always ready for use



### **QUICK-CLIP**

### **RECOVERY TANK**

The dirty water tank detaches and reattaches easily with the **QUICK-CLIP** system. Its design ensures complete emptying and prevents residue that could cause mold and unpleasant odors.

## PRO PERFORMANCE IN A MINI SIZE

V1 can clean the same square meters as a conventional floor scrubber, delivering the same performance.

However, thanks to its ultra-compact size, it can reach areas where others cannot, cleaning up to 60% more surface area.

### Mini FOOTPRINT

V1 provides the **SAME PERFORMANCE AND THE SAME POWER** as a conventional 50 cm scrubber dryer, and more:

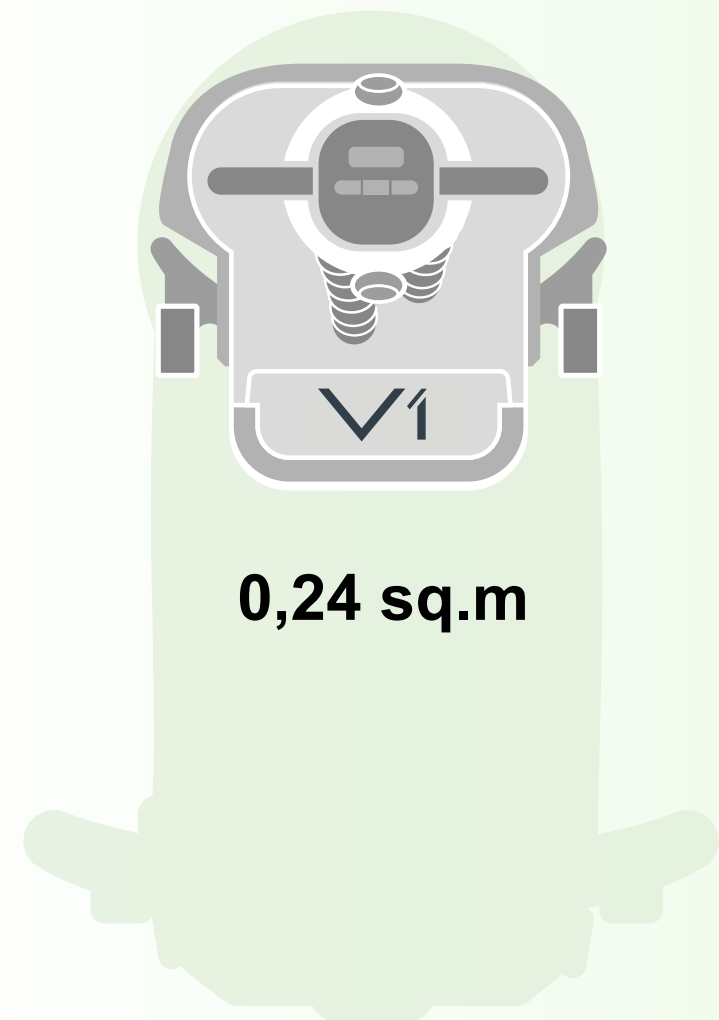

Reduction in packaging, transport costs,  
and CO<sub>2</sub> emissions

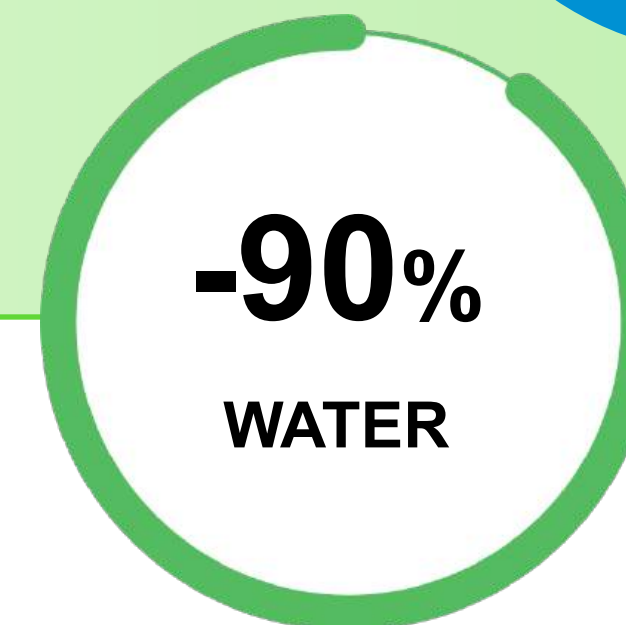
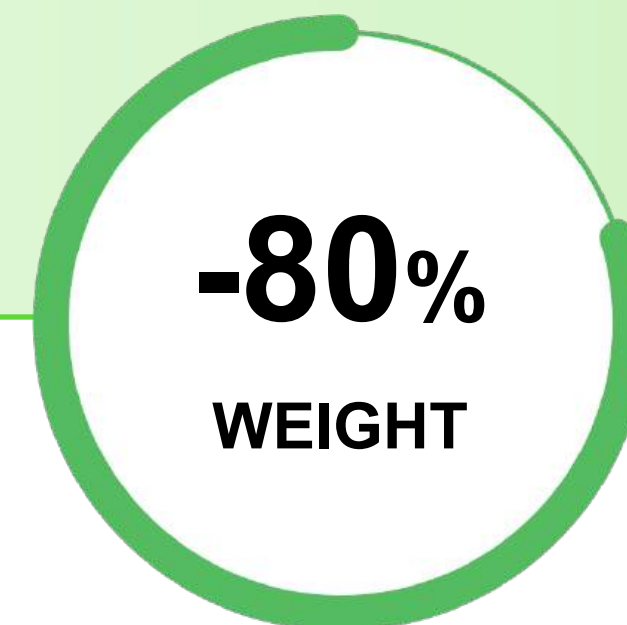

Resource savings

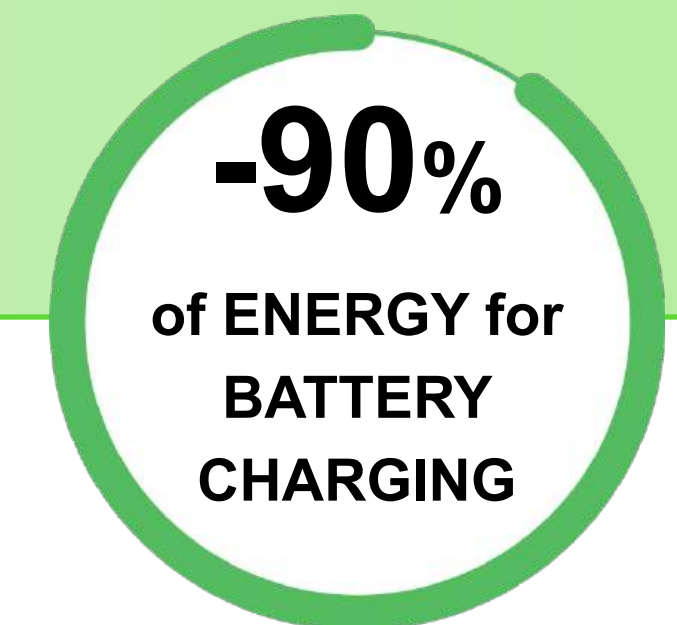

It charges in just 2 hours with lithium  
batteries, compared to the 12 hours  
required for a floor scrubber with  
conventional batteries





# PVA VS WBA

**— PVA** PROFESSIONAL VERTICAL AUTOSCRUBBER

**— WBA** WALK BEHIND AUTOSCRUBBER



## PRODUCTIVITY THEORETICAL

1800 m<sup>2</sup>/h vs 2000 m<sup>2</sup>/h

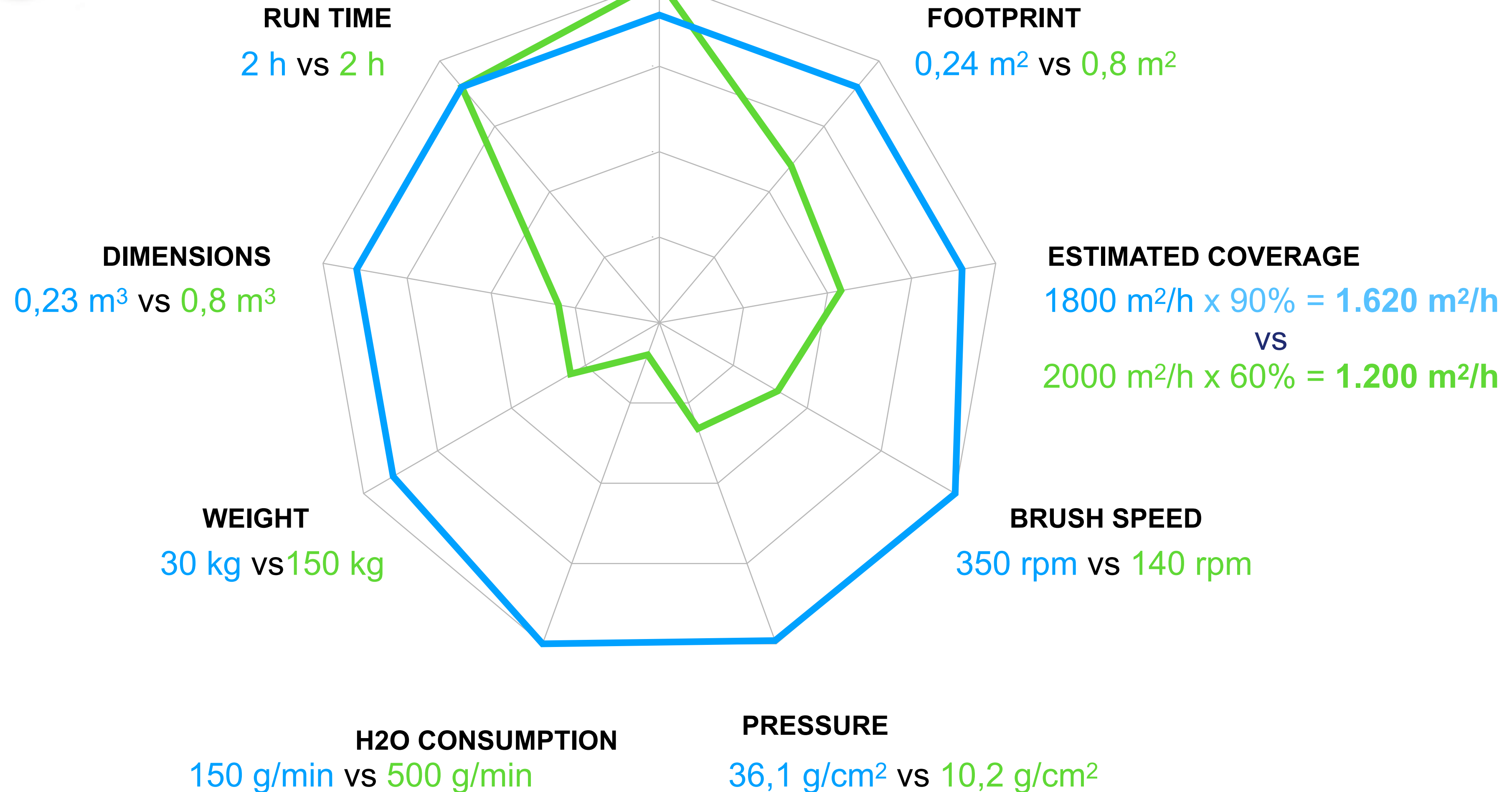

**With V1, you increase the cleaning surface coverage,  
saving time and achieving a QUICK RETURN  
ON YOUR INITIAL INVESTMENT**



In an environment such as an office, a conventional scrubber dryer cannot clean the entire floor area.

Tables and furniture block the passage, leaving much of the floor to be cleaned, often up to 50%.

V1, on the other hand, can clean along narrower passages and flexes to reach under tables, covering up to 90 % of the usable area.

**Batteries  
and battery chargers**



**BATTERIES**  
Time to full charge  
 



**Battery charger 24V 10A\***  
9200041 EU

**Battery charger 24V 15A\***  
9200042 EU

	24 V / 15 Ah 461426	24 V / 25 Ah 461427
1h 30' (90')	-	-
-	-	1h 40' (100')

\* Battery charger are already supplied with their respective cables

**CABLES AVAILABLE FOR CHARGERS**



421360 EU



425678 UK



421359 US



452508 AU



452475 JP











452474 CN



## Brushes and pads for any cleaning needs

V1 is a powerful and versatile machine able to perform any treatment on any type of floor.

The wide range of brushes and pads available can handle everything from the most difficult dirt to simple daily maintenance cleaning and polishing of delicate surfaces.

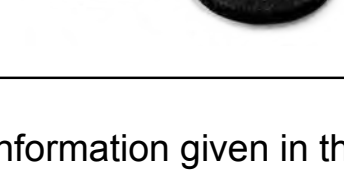





	CODE	DESCRIPTION	COLOUR	TYPE OF CLEANING
		<b>DISC BRUSHES</b>		
	9400151	SOFT BRUSH PPL 0,3	BLACK	Suitable for light and frequent cleaning of delicate hard and wooden floors such as marble and parquet.
	9400152	MEDIUM BRUSH PPL 0,45	LIGHT BLUE	Suited for daily and maintenance cleaning of all types of vinyl and hard floors. It is effective on PVC, linoleum, concrete or stone surfaces, even uneven or with grout lines. <b>Provided as standard</b>
	9400153	HARD BRUSH PPL 0,6	WHITE	For heavy-duty and maintenance cleaning of hard floors, including linoleum, stone or tiles, even with uneven surfaces.
	9400154	NATURAL FIBRE BRUSH	GOLD	Suitable for vinyl and wooden floors for cleaning and polishing. It is effective on linoleum, PVC, resin, porcelain stoneware, wood, parquet, sports floors.
		<b>ABRASIVE PADS</b>		
		Pads suited for ordinary and extraordinary cleaning of porcelain, tuff or microporous surfaces. For polishing resin or concrete floors. They are not for use on uneven or jointed floors.		
	9400158		WHITE	Soft pad for finishing wax/oiled surfaces and fine polishing.
	9400155		RED	Medium-soft pad for daily maintenance of any type of flooring and for polishing wax/oiled surfaces.
	9400156		GREEN	Medium-hard pad for maintenance and heavy-duty cleaning of resistant floors and for dewaxing.
	9400159		BROWN	Heavy duty pad for wet and dry scraping and for heavy-duty cleaning of resistant floors.
	9400157		BLACK	Hard pad for heavy duty cleaning of resistant floors with stubborn dirt and for dewaxing with chemicals.

The information given in the table is for general purposes. For more detailed information on the brushes or pads to be used, please follow the floor manufacturer's specific recommendations.

## Brushes and pads for any cleaning needs

V1 is a powerful and versatile machine able to perform any treatment on any type of floor.

The wide range of brushes and pads available can handle everything from the most difficult dirt to simple daily maintenance cleaning and polishing of delicate surfaces.

	CODE	DESCRIPTION	COLOUR	TYPE OF CLEANING
		<b>DIAMOND PADS</b> Diamond pads are suited for polishing and sanding non-smooth surfaces as they remove dirt and damage caused by wear. For polishing and sanding, it is recommended to use the pads in progression from the coarsest to the lightest grit.		
	9400160	500 GRIT	LIGHT BLUE	It removes excess densifier leaving a matt finish, it also removes marks and small scratches from the surface.
	9400161	1000 GRIT	RED	Suited for a satin finish. It is recommended after using the Light Blue pad (500 grit).
	9400162	2000 GRIT	BEIGE	For a semi-gloss finish. It is recommended after using the Red pad (1000 grit).
	9400163	5000 GRIT	WHITE / BEIGE	For a gloss finish. It is recommended after using the Beige pad (2000 grit).
		<b>MICROFIBRE PAD</b>		
	9400164		WHITE	Suitable for frequent and maintenance cleaning, and for protective and polishing treatments of delicate, wooden and parquet floors. It is recommended after using the White/Beige pad (5000 grit).
		<b>PAD HOLDERS</b>		
	9400165	FOR ALL PADS		
	9400166	FOR MICROFIBRE PADS		

TECHNICAL DATA		
Productivity	up to sqm/h	1380
SCRUBBING SYSTEM		
Working width	mm	460
Brush motors	(no.) V/W	(2) 24/310
Brush speed	rpm	350
Pressure on the brushes	up to kg	30
TANK AND RECOVERY SYSTEM		
Solution tank	l	5
Recovery tank	l	6
Suction motor	V/W	24/200
BATTERY		
Supply / Traction	V/Hz	24 / Semi aut.
Battery / Run time*	(no.) V/Ah / h	(1) Lithium 24/15 / 1h (60') (1) Lithium 24/25 / 2h (120')
SPECIFICATIONS		
Machine dimensions (L x h x w)	mm	505 x 1170 x 470
Squeegee width	mm	505
Machine weight empty without batteries	kg	24
Sound level (ISO 11201) - Eco mode	dB (A)	<70
BATTERY CHARGING TIME		
	24 V / 15 Ah	24 V / 25 Ah
Battery charger 10A	1h 30' (90')	2h 30' (150')
Battery charger 15A	-	1h 40' (100')

\* Run times are based on continuous scrubbing run times

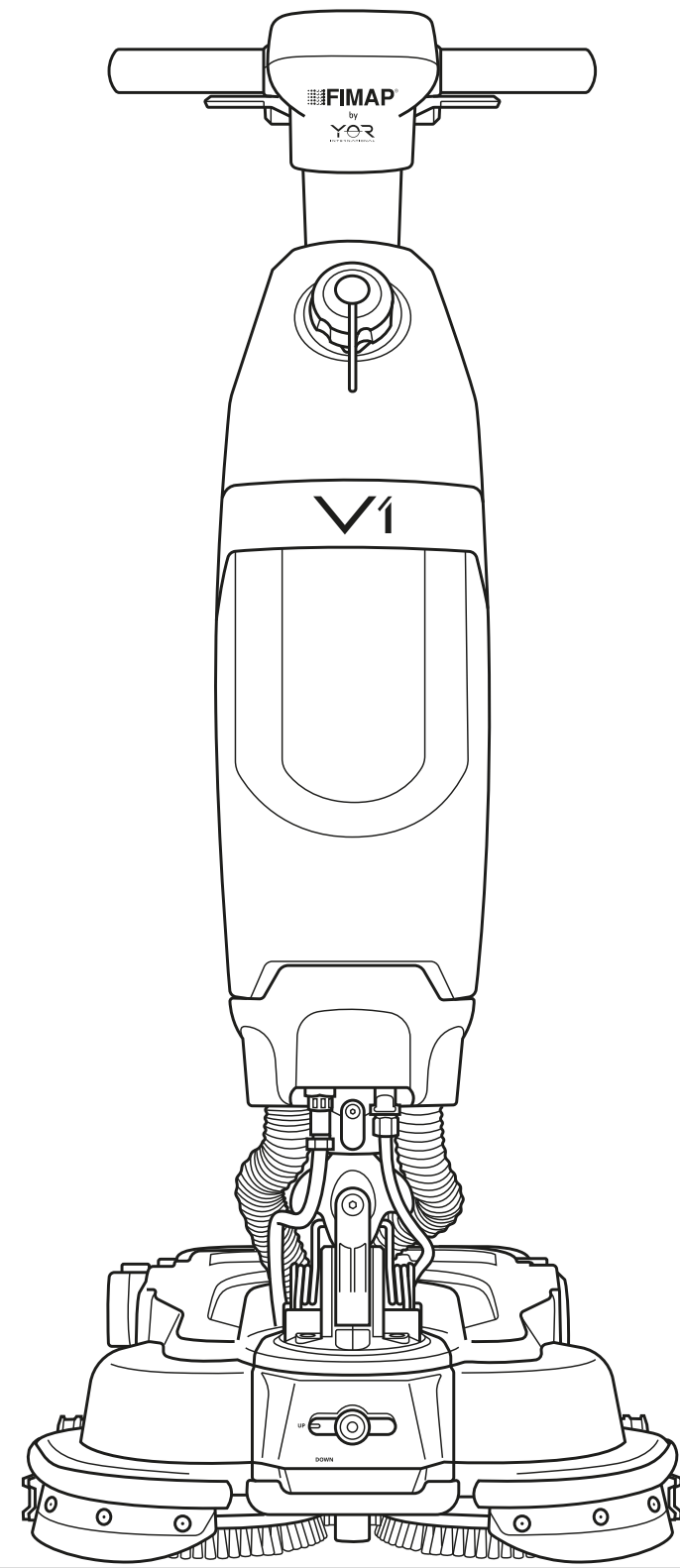

Scrubbing path  
460 mm

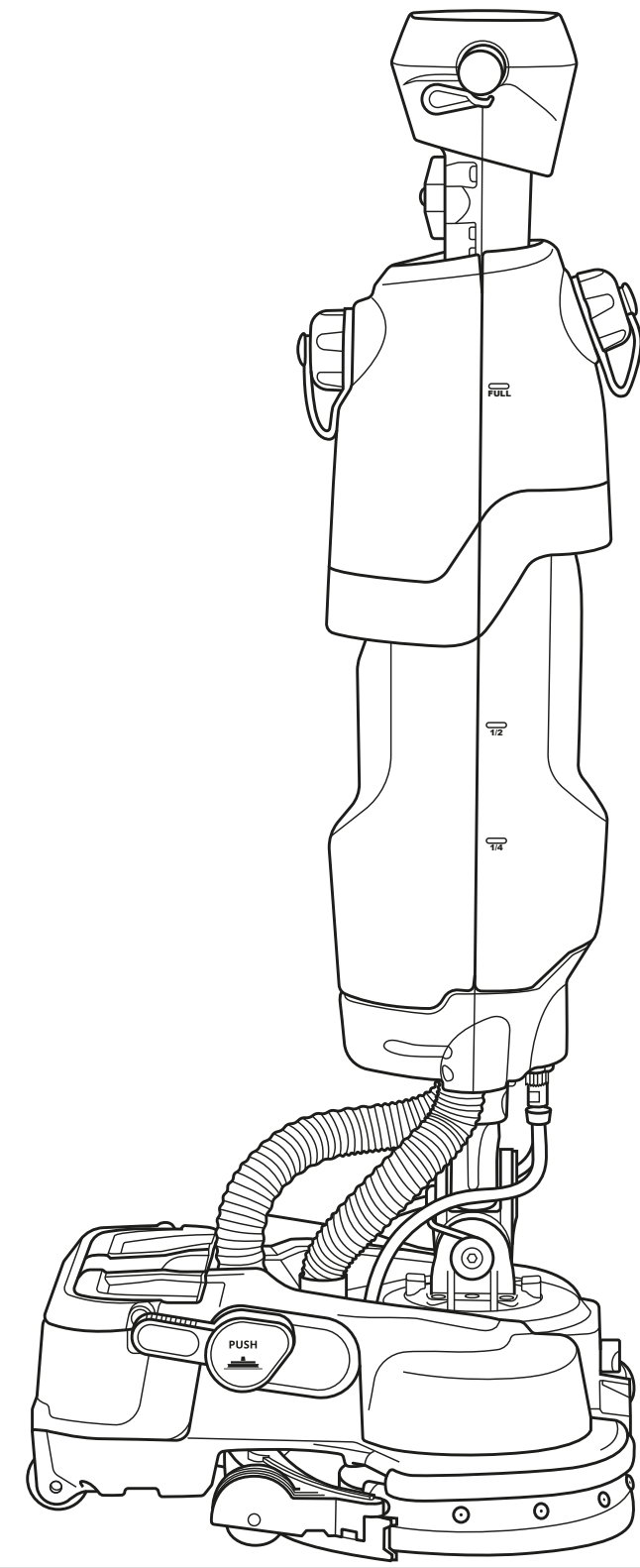

1170 mm

470 mm

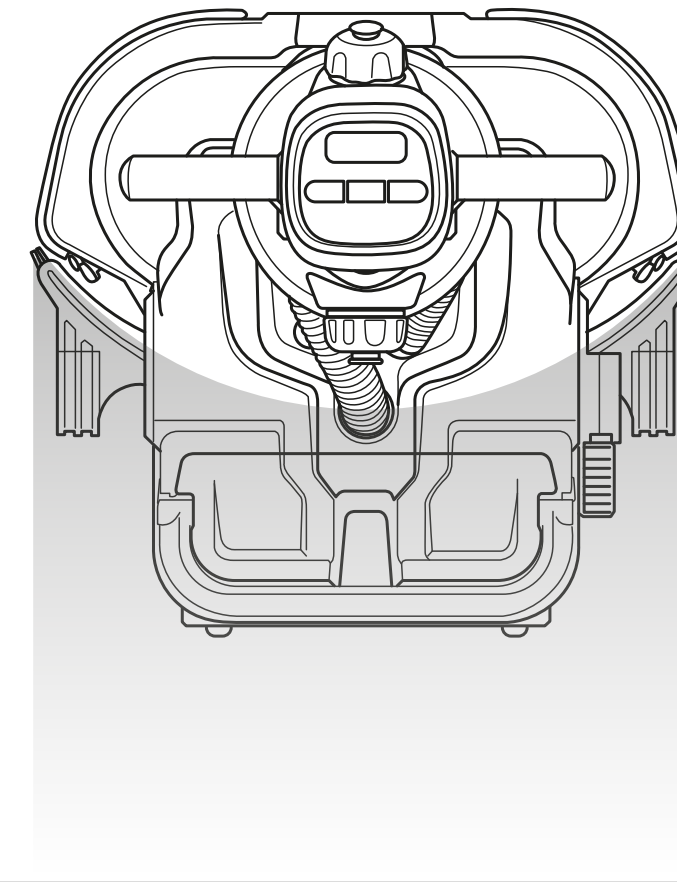

Drying path  
505 mm

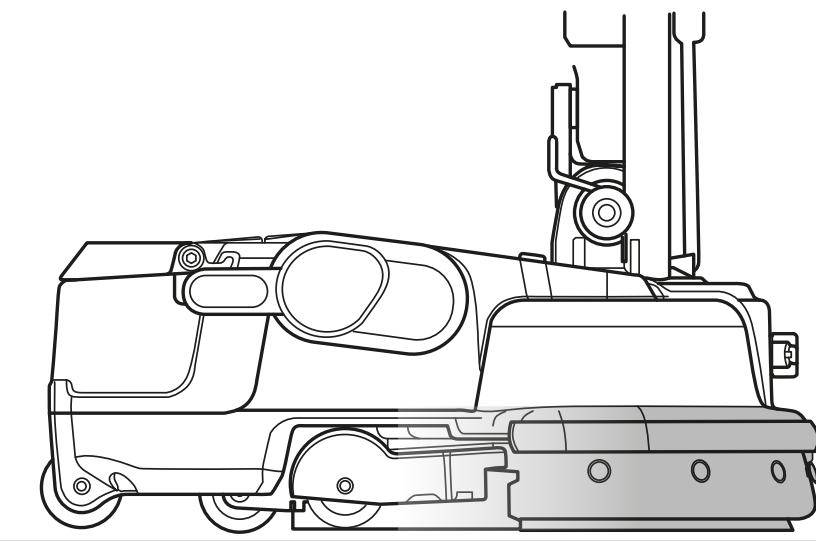

70 mm





**Ownership of the information and/or documents:**

All information (by which we mean all data and information with the sole exception of that of common knowledge or which FIMAP has disclosed without reserve) and all documents (drawings, photos, etc.) are the exclusive property of FIMAP and their use does not mean there is any kind of acquisition of titles, property or exploitation of rights or licences except for the limited permission of use ruled by this document.

By way of example and, therefore, not limited to, such information and/or documents can be the following:

**Marketing section:**

high definition digital images for the implementation of commercial catalogues on paper or web sites, company trademarks, original graphical documents from which texts are taken (e.g. the descriptive notes), PDF documents and original documents in .ppt format.

**Professional use of the data:**

It is a known fact that the information and/or documents, subject of this commitment, are and will be used by the beneficiary exclusively for carrying out his professional business and, therefore, no specific laws regarding consumer protection are applicable.

**Confidentiality:**

The Party that benefits from the information or use of documents taken from or, in any case, part of the commercial documentation, shall use all such information and/or documents with maximum care solely for the purposes connected to execution of this contract with FIMAP and shall:

keep such information and/or documents confidential except for those, due to their nature, which are to be disclosed (promo-advertising material etc.);

shall not divulge any information and/or document to its suppliers, collaborators or employees beyond what is strictly necessary so that they may fulfil their tasks concerning relations with FIMAP and shall ensure that the suppliers, collaborators and employees that have access to the information and/or documents are, in turn, bound by a confidentiality commitment to the benefit of FIMAP; shall not divulge any information to third parties without the prior written consent by FIMAP; copy and/or in any other way reproduce any information or document without the prior written consent of FIMAP; take all the necessary measures to protect confidentiality.

**Returning Information and/or documents:**

Whilst maintaining exclusive ownership at all times, FIMAP has the right, at any time, to ask in writing or by e-mail, that all the information and/or documents received be returned or no longer used and within the term of thirty days from receipt of this request, all the information and/or documents must be returned, including any copies, or destroy such information and/or documents and relative copies so as to prevent them from being recovered and FIMAP must be given a written declaration certifying that the information and/documents have all either been returned or destroyed.

This obligation to return, destroy or no longer use is set automatically in motion when the relationship is cancelled with FIMAP for any reason whatsoever.

**Applicable law, cancelling clauses and Court having jurisdiction:**

The interpretation, integration, execution and the effects of this commitment will be governed by Italian law.

If one or more points of this agreement are cancelled it does not invalidate the remaining points.

All disputes will be put to the exclusive jurisdiction of the Verona Courts.